

TOF Series Sensor User Manual



Language: English

Firmware: V1.1.9

Catalogue

Catalogue	2
1 Introduction	4
2 UART Output	4
2.1 Active Output	4
2.2 Query Output	5
3 IIC Output	5
4 I/O Output	6
4.1 Single Threshold	6
4.2 Double Threshold	7
5 Low Power	8
6 FOV	8
7 Protocol Unpack	9
7.1 Introduction	9
7.2 Composition	9
7.2.1 UART	9
7.3 Example	10
7.3.1 NLink_TOFSense_Frame0	10
7.3.2 NLink_TOFSense_Read_Frame0	10
7.3.3 NLink_TOFSense_F_Setting_Frame0	11
7.3.4 NLink_TOFSense_IIC_Frame0	12
8 FAQ	14
9 Reference	16
10 Abbreviation and Acronyms	16

1 Introduction

This document mainly introduces how to use the SEN0646, SEN0647 and SEN0648, as well as the precautions to be taken during use. You may need to refer to the following information for assistance in understanding:

2 UART Output

UART mode has two output modes: active output and query output. The two output modes can be switched by modifying the data output mode on NAssistant.

Connect TOFSense-F/F2 series products to NAssistant through USB to TTL module (Reference datasheet for Line Sequence and Power Supply). After successful recognition, click  to enter the settings page. After configuring the parameters, click the write parameter button to save the parameters. After the parameters are successfully written, it is possible to read them once to confirm whether the parameters were successfully written.

2.1 Active Output

UART active output mode can be used in single module.

The interface type is set to UART, the data output mode is set to Active, and the UART active output mode configuration is shown in Figure 1. In this mode, TOFSense F/TOFSense F P module defaults to 50Hz (up to 350Hz) , TOFSense F2 and TOFSense F2 P module defaults to 50Hz (up to 100Hz) , TOFSense F2 Mini actively outputs measurement information at a frequency of 50Hz. The output format follows the NLink_TOFSense_Frame0 protocol.

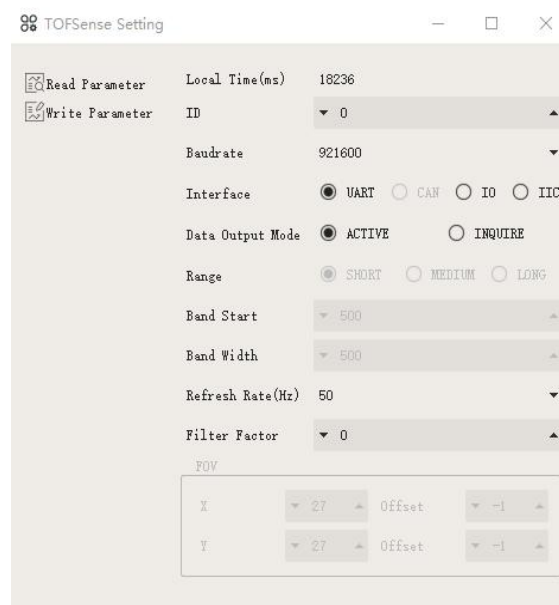

Figure 1: Configuration Diagram For UART Active Output Mode

2.2 Query Output

The UART query output mode can be used in single module.

Set Interface type as UART, set Output mode as INQUIRE. The configuration of UART query output mode is shown in Figure 2. After Write Parameter module is restarted, it will no longer actively report data.

In this mode, the controller sends a query instruction containing the module ID to the expected query module, and the module can output one frame of measurement information. The query frame format follows the protocol NLink_TOFSense_Read_Frame0, and the output frame format follows the protocol NLink_TOFSense_Frame0.

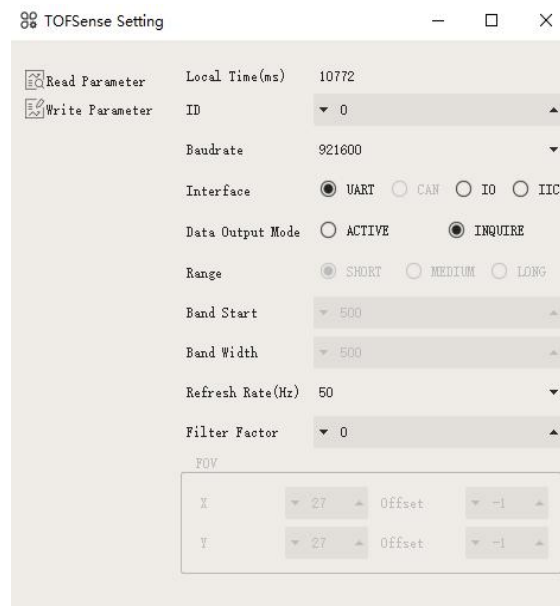



Figure 2: Configuration Diagram for UART Query Output Mode

3 IIC Output

The IIC mode can be used in both single module and cascading scenarios. In IIC communication mode, the controller sends a read frame to the expected query module at the specified slave address according to the IIC communication timing to obtain the module's distance and other related information. In addition, the output mode and other parameters of the module can also be changed through IIC communication. The format of reading and writing frames follows the protocol NLink_TOFSense_IIC_Frame0.

When the module is in UART mode (note that NAssistant cannot recognize the module in IIC mode), connect TOFSense-F series product to NAssistant through the USB to TTL module (line sequence and power supply voltage reference datasheet). After successful recognition, click  to enter the settings page. The IIC output mode configuration is shown in Figure 3. The IIC slave address of the module can be changed by setting the module ID (7-bit slave address is 0x08+module ID, ID setting range is 0~111). After configuring the parameters, click the write parameter button to save the parameters. Note: After switching to IIC mode, you can refer to the method in the FAQ chapter to change back to UART mode.

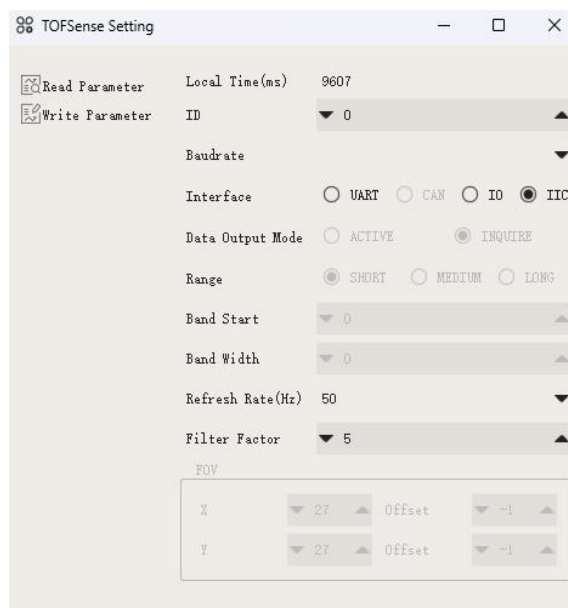



Figure 3: Configuration Diagram for IIC Output Mode

4 I/O Output

In I/O output mode, it can only be used in a single module. The module cannot output distance values. TX/IIC_CLK and RX/IIC_SDA output complementary voltage levels, with the electrical states of the two signal lines being opposite to each other. The high level is 3.3V, and the low level is 0V. Additionally, it's important to note that the output current is relatively low, so when driving other devices, it's necessary to consider whether the CAN signals can directly drive them. If not, methods such as using relays can be employed for driving purposes.

When the module is in UART mode (Note that NAssistant cannot recognize modules in I/O mode), Connect TOFSense series products to the NAssistant through the USB to TTL module (line sequence and power supply voltage reference datasheet). After successful recognition, click  to enter the settings page. After configuring the parameters, click Write Parameter button to save the parameters.

Note: After switching to I/O mode, if you need to change parameters such as BandsStart and Bandwidth, you can refer to the methods in the FAQ to change back to UART mode and then configure it.

4.1 Single Threshold

The interface type is set to IO, Band Start is set to 1000, Band Width is set to 0, and the IO single threshold configuration is shown in Figure 4. After the write parameter module is restarted, it will no longer output ranging values but output high and low levels.

After following the above settings, the threshold is BandStart=1000 (mm). In this mode, when the ranging value is less than 1m, RX is at a high level and TX is at a low level. When the ranging value is greater than 1m, RX is at a low level and TX is at a high level.

Example: When the ranging value is 0.3 meters, RX is high level and TX is low level. The ranging value increases to 1.2 meters, RX is low level, and TX is high level.

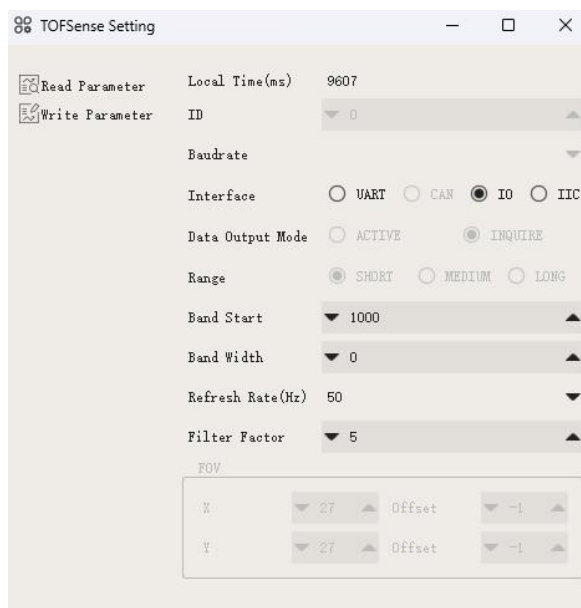

Figure 4: I/O Mode Single Threshold Setting

4.2 Double Threshold

The interface type is set to IO, the hysteresis starting point Band Start is set to 1000, and the hysteresis width Band is set to 500. The IO dual threshold configuration is shown in Figure 5. After the parameter module is written and restarted, it will no longer output ranging values but output high and low levels.

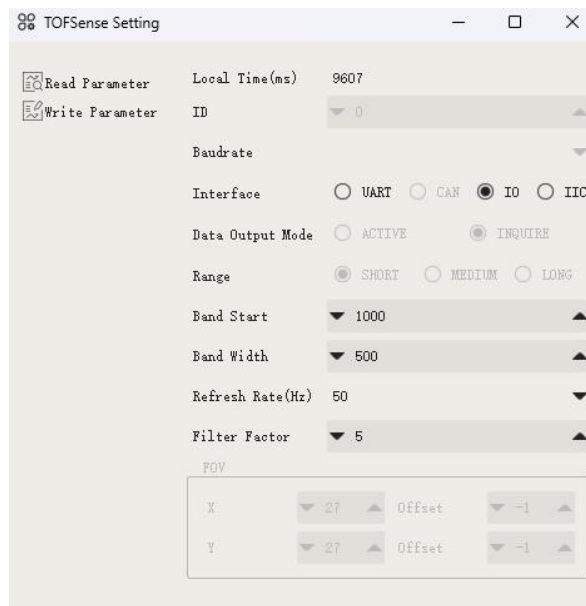

Figure 5: I/O Mode Dual Threshold Setting

After following the above settings, the distance value in this mode is converted into high and low level output through hysteresis comparison. Invert the I/O port level when the distance increases from small to large and exceeds the high threshold, or when it decreases from large to small and falls below the low threshold.

For example, based on the above settings, the low threshold is 1 meter and the high threshold is 1.5 meters. (Low threshold=hysteresis starting point Band Start, high threshold=hysteresis starting point Band Start+hysteresis width Band Width)

When the ranging value is 0.3 meters, RX is at a high level and TX is at a low level;

When the distance measurement value increases to 1.2 meters, RX is at a high level and TX is at a low level;

When the distance measurement value continues to increase by more than 1.5 meters, the level reverses, with RX being the low level and TX being the high level.

When the ranging value drops from over 1.5 meters to 1.2 meters, RX is at a low level and TX is at a high level.

When the distance measurement value continues to drop below 1 meter, the level reverses, with RX being the high level and TX being the low level.

The schematic diagram of hysteresis loop comparison is shown in Figure 7, where BandnStart and BandWidth values of TOFSense F/TOFSense F P range from [0~15000]/[0~25000], unit: mm.

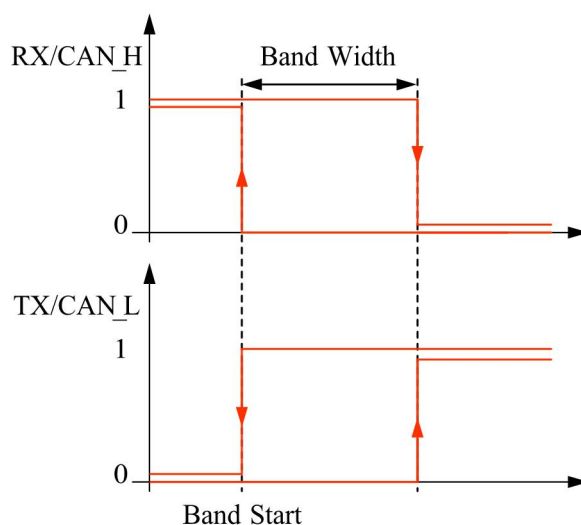

Figure 7: Schematic Diagram Of Hysteresis Loop Comparison

5 Low Power

Not yet open. If you have any requirements, please contact the original factory.

6 FOV

The field of view angle parameter represents the angle that the module can cover by emitting ranging light. The field of view angle parameters of the module are 1-2 ° and 2-3 °. As shown in the figure below, the FOV region of the TOFSense F series is a cone with a circular vertex at the bottom in the emission window. Taking a 2 ° field of view angle as an example, when facing a sufficiently large object under test, the diameter of the FOV coverage circle on the measured plane can be estimated by trigonometric function to be $R=L*\tan 2^\circ$ (L: the distance between the TOFSense F series module and the object under test). When multiple measured objects are present within the FOV range of the module, as shown in Figure 7, the output measurement value will be abnormal. If high accuracy is required during use, such situations should be avoided as much as possible to reduce measurement errors.



Figure7: Multiple Tested Objects Exist Simultaneously Within The Range

7 Protocol Unpack

7.1 Introduction

This chapter's protocol parsing example is based on NLink protocol, and NlinkUnpack sample parsing code developed in C language can be downloaded from the official website, which can effectively reduce the user development cycle.

According to the data situation of the TOFSense F series products, in order to represent more data with fewer bytes as much as possible, we use integer to represent floating-point numbers, which are transmitted through protocol frames. Therefore, when unpacking, the integer data with a multiplier is actually floating-point, and needs to be divided by the multiplier identified in the protocol.

Specifically, for the int24 type, we need to convert it to the int32 type first. To maintain the symbol unchanged, we use a left shift and divide by 256. For example, for location data, we use int24 to represent it, with a multiplication rate of 1000. The parsing code is as follows:

```
uint8_t byte[] = {0xe6,0x0e,0x00}; //Representative decimal value: 3.814
//uint8_t byte[] = {0xec,0xfb,0xff}; //Representative decimal value: -1.044
int32_t temp = (int32_t)(byte[0] << 8 | byte[1] << 16 | byte[2] << 24) / 256;
float result = temp/1000.0f;
```

At present, protocol verification mainly involves checking the sum of the last single byte of the protocol frame.

Example code:

```
uint8_t verifyChecksum(uint8_t *data, int32_t length){
    uint8_t sum = 0;
    for(int32_t i=0;i<length-1;++i){
        sum += data[i];
    }
    return sum == data[length-1];
}
```

7.2 Composition

7.2.1 UART

The default configuration of the serial port is: data bit 8 bit, stop bit 1 bit, no parity check, no flow control,

default baud rate 921600bps.

Each data frame containing distance under the UART interface consists of 16 bytes of hexadecimal numbers. The distance and other data are arranged in small end mode. The format of the serial communication output protocol data frame is shown in Table 1. The Protocol consists of Frame Header, Function Mark, Data, and Sum Check.

Table 1: Protocol Composition



Frame Header: Frame header, fixed to 0x57.

Function Mark: Function word, the output protocol frame bit is fixed as 0x00, and the query protocol frame bit is fixed as 0x10.

Data: Data segment, the output protocol frame includes module ID, system time “System_time”, measured value “dis”, distance status “dis status”, and signal strength “signal strength”. The query protocol frame only contains the ID of the queried module.

Sum Check: Checksum, which calculates the sum of all bytes from Frame Header to Data, taking the lower 8 bits.

The output protocol frame can be found in Table 2: NLink_TOFSense_Frame0 parsing table, while the query protocol frame can be found in Table 3: NLink_TOFSenseRead_Frame0 parsing table.

7.3 Example

This document takes single module continuous ranging as the application scenario.

7.3.1 NLink_TOFSense_Frame0

Data source: Connect the module to the host computer, configure UART as active output mode, using NLink_TOFSense_Frame0 protocol. For parsing distance data, please refer to the FAQ.

Raw data: 57 00 ff 00 9e 8f 00 00 ad 08 00 00 03 00 06 41

Tabel 2: NLink_TOFSense_Frame0

Data	Type	Length (Bytes)	Hex	Result
Frame Header	uint8	1	57	0x57
Function Mark	uint8	1	00	0x00
reserved	uint8	1	...	*
id	uint8	1	00	0
System_time	uint32	4	9e 8f 00 00	36766ms
dis*1000	uint24	3	ad 08 00	2.221m
dis_status	uint8	1	00	0
signal_strength	uint16	2	03 00	3
range_precision	uint8	1	06	6cm
Sum Check	uint8	1	41	0x41

7.3.2 NLink_TOFSense_Read_Frame0

Data source: Connect the module to the host computer, configure it as UART query output mode with ID set to 0. To query data, send the following bytes from the host computer. If you need to query modules with different IDs, simply change **ID and checksum** accordingly.

Example: The module query instruction for id=3 should be: 57 10 FF FF 03 FF FF 66

Raw data: 57 10 FF FF 00 FF FF 63

Table 3: NLink_TOFSense_Read_Frame0

Data	Type	Length (Bytes)	Hex	Result
Frame Header	uint8	1	57	0x57
Function Mark	uint8	1	10	0x10
reserved	uint16	2	...	*
id	uint8	1	00	0
reserved	uint16	2	...	*
Sum Check	uint8	1	63	0x63

7.3.3 NLink_TOFSense_F_Setting_Frame0

This protocol is a parameter setting protocol for modules, which can be modified through serial port instructions. This function is an advanced function. If the module parameters are modified incorrectly, it may cause the module to not function properly. It is recommended to have a certain understanding of the entire system parameters before using this function.

Table 4: NLink_TOFSense_Read_Frame0

Data	Type	Length (Bytes)	Description
Frame Header	uint8	1	value = 0x54
Function Mark	uint8	1	value = 0x20
mix	uint8	1	bit0: [0:write],[1:read]---WO
reserved	*	1	Reserved.The default value is 0xFF
id	uint8	1	Node ID---RW
system_time	uint32	4	terminal system time,unit:ms---WO
			node system time,unit:ms---RO
mode	uint8	1	bit1:output mode-[0:active],[1:inquire]---WR
			bit2-3:range mode-[00:short],[01:medium],[10:long]---WR
			bit4:0:interface mode-[00:uart],[01:can],[10:io],[11:iic]---WR
			bit5: Low power
reserved	*	2	Reserved.The default value is 0xFF
uart_baudrate	uint24	3	UART:4800,9600,14400,19200,38400,43000,57600,76800,115200,230400,460800,921600,1000000,1200000,1500000,2000000,3000000
			CAN:100000,250000,500000,1000000,2000000,3000000
reserved	uint8	4	Reserved.The default value is 0xFF
band_start	uint16	2	[0,25000],unit:mm
band width	uint16	2	[0,25000],unit:mm
reserved	uint8	1	Reserved.The default value is 0xFF
refresh rate	uint16	2	Data refresh rata:1,2,5,10,25,50,100,200,350Hz
filter factor	uint8	1	Filter factor: 0~255.Default:5
reserved	uint8	4	Reserved.The default value is 0xFF

Sum Check	uint8	1	Sum Check is equal to all previous bytes added
-----------	-------	---	--

7.3.4 NLink_TOFSense_IIC_Frame0

Slave address: The module acts as a slave on the IIC bus and its default address is 0x08 (7-bit address). The slave address is 0x08 + module ID, so changing the module's ID will change the slave address. When communicating, it is important to pay attention to address shifting and adding the read/write bit, i.e., when the address is 0x08, the byte with the read/write bit is 0x10 (write) or 0x11 (read).

Register address: If there is no corresponding parameter in the register, the default output is 0xff.

Table 5: NLink_TOFSense_IIC_Frame0 Register Map and Communication Flow Chart

Start Address	Bit																															R/W	
0x00	31	30	29	28	27	26	25	24	23	22	21	20	19	18	17	16	15	14	13	12	11	10	9	8	7	6	5	4	3	2	1	0	RO
	Reserved															Product Version																	
	[15-0] Product Version																																
0x04	31	30	29	28	27	26	25	24	23	22	21	20	19	18	17	16	15	14	13	12	11	10	9	8	7	6	5	4	3	2	1	0	RO
	Bootloader version															Hardware Version																	
	[15-0] Hardware Version																																
0x08	31	30	29	28	27	26	25	24	23	22	21	20	19	18	17	16	15	14	13	12	11	10	9	8	7	6	5	4	3	2	1	0	RO
	Firmware Version																																
	[0-31] Firmware Version																																
0x0C	31	30	29	28	27	26	25	24	23	22	21	20	19	18	17	16	15	14	13	12	11	10	9	8	7	6	5	4	3	2	1	0	RW
	Reserved															ID						Reserved	Low Power	Reserved	Output mode	Interface mode							
	[0-2] Interface mode: 0-UART , 1-CAN , 2-I/O , 3-IIC (RW)																																
	[3] Output mode: 0-Active Output, 1-Query Output(RO)																																
	[6]Low power mode: Enable low power mode, 0-Disable, 1-Enable(Not yet open. If you need to use it, please contact the original factory)																																
	[8-15] ID: Device ID (RW), the slave address will take effect only after a power cycle after changing the ID.																																
0x10	31	30	29	28	27	26	25	24	23	22	21	20	19	18	17	16	15	14	13	12	11	10	9	8	7	6	5	4	3	2	1	0	RW
	UART Baudrate																																
[0-31] Uart Baudrate																																	
0x14-0x18	Reserved																															RO	
	Reserved																																
0x1C	31	30	29	28	27	26	25	24	23	22	21	20	19	18	17	16	15	14	13	12	11	10	9	8	7	6	5	4	3	2	1	0	RW
	Bandwidth															Bandstart																	
	[0-15] bandstart: I/O mode latency start, unit: mm																																
[16-31] bandwidth: I/O mode loop bandwidth, unit: mm																																	
0x20	31	30	29	28	27	26	25	24	23	22	21	20	19	18	17	16	15	14	13	12	11	10	9	8	7	6	5	4	3	2	1	0	RO
	SysTime																																

	[0-31] Sysstime: system time, unit: ms																																
0x24	31	30	29	28	27	26	25	24	23	22	21	20	19	18	17	16	15	14	13	12	11	10	9	8	7	6	5	4	3	2	1	0	RO
	Distance																																
	[0-31] distance: The distance,unit: mm																																
0x28	31	30	29	28	27	26	25	24	23	22	21	20	19	18	17	16	15	14	13	12	11	10	9	8	7	6	5	4	3	2	1	0	RO
	signal_strength																dis_status																
	[0-15] dis_status: The distance status																																
	[16-31] signal_strength																																
0x2C	31	30	29	28	27	26	25	24	23	22	21	20	19	18	17	16	15	14	13	12	11	10	9	8	7	6	5	4	3	2	1	0	RW
	filter factor								refresh rate												range_precision												
	[0-7] Range_precision: Measurement accuracy, unit: cm, 0xFF represents greater than or equal to 255cm, 0x00 represents less than 1cm.																																
	[8-23] Refresh rate: unit: Hz																																
	[24-31] Filter factor: 0-255, Default: 5																																

IIC communication process:

Single Data Write

Start	Slave Addr W	ACK	Reg Addr	ACK	Data[7:0]	ACK	Stop
-------	--------------	-----	----------	-----	-----------	-----	------

Signal Data Read

Start	Slave Addr W	ACK	Reg Addr	ACK	Stop
Start	Slave Addr R	ACK	Data[7:0]	NACK	Stop

Multiple Data Write

Start	Slave Addr W	ACK	Reg Addr	ACK	Data[7:0]	ACK	Data[7:0]	ACK	Data[7:0]	ACK	Stop
-------	--------------	-----	----------	-----	-----------	-----	-----------	-----	-----------	-----	------

Multiple Data Read

Start	Slave Addr W	ACK	Reg Addr	ACK	Stop				
Start	Slave Addr R	ACK	Data[7:0]	ACK	Data[7:0]	ACK	Data[7:0]	NACK	Stop

Start: Start signal

W: Read flag 1

R: Write flag 0

ACK: Acknowledge

NACK: Non-acknowledge

Stop: Stop signal

	Host sends
	Slave sends

8 FAQ

Q1. Can it be used outdoors (in bright light) conditions?

The module is affected by natural light. Generally speaking, the stronger the natural light, the more it will be affected, resulting in shorter ranging distance, poorer accuracy, and larger fluctuations. In strong light conditions (such as sunlight), it is generally recommended to use the module for short-range detection scenarios.

Q2. Is there interference between multiple modules?

When multiple modules are working at the same time, even if the infrared light emitted from one module crosses or hits the same position as another module, it will not affect the actual measurement. However, if two modules are at the same horizontal height and facing each other, the measurement may be affected for both of them.

Q3. Does the reflectivity of an object's surface affect the sensor?

Yes, the sensor's range and accuracy can be influenced by the reflectivity of the measured object. In the same environment, measurements may vary for objects with different reflectivity. Therefore, users are advised to conduct sufficient testing in the actual scene and calibrate the sensor as needed for more accurate results. Suggest comparing the test data of cardboard and the one of the actual object being tested, analyzing and compensating for and optimizing based on signal strength.

Q4. Why is there no data output from TOFSense-F?

Each module has undergone strict testing before shipping. If there is no data, please first check if the Mode, wiring (power supply voltage, wire sequence correctness, and whether the pins on both sides of the communication are conducting as recommended by using a multimeter to test), Baud Rate and other configurations are correct. For the IIC output mode, it is necessary to use the host to read data from the set slave address through IIC communication according to the communication sequence in the manual; For the I/O output mode, please refer to the relevant chapters on I/O mode.

Q5. What should be noted during installation?

If you do not want to detect the ground or other reflective surfaces, it is necessary to avoid obstructions within the FOV angle during installation. Additionally, the ground height should be taken into consideration, and it is necessary to avoid obstructions such as ground reflections within the FOV. If the installation height is close to the ground, the module can be slightly tilted upwards for installation.





Q6. Are the module's UART, IIC, and I/O the same interface?

UART, IIC and I/O interfaces of the module share the same physical interface. To switch between different communication modes, simply convert the corresponding wire sequence.

Q7. Why can't NAssistant recognize the module after switching to IIC or I/O mode? How to switch between different communication modes?

At present, NAssistant only supports recognizing modules in UART mode. When in UART mode, the module can be configured to IIC or I/O communication mode by entering the settings page after successful recognition by the host computer; In IIC communication mode, instructions can be sent to the module through IIC

communication according to the IIC communication protocol to switch back to UART or I/O mode; In addition, in the absence of IIC testing environment or after switching to I/O mode, you can switch back to UART mode by the following methods:

1. The user needs to prepare a USB to TTL module that supports 921600 baud rate (CP2102 is recommended) and install the corresponding driver, connect the USB to TTL module's TX, RX, and GND to the corresponding pins of the TOF module, and temporarily not connect the VCC pin. Then plug the USB to TTL module into the computer.
2. Open NAssistant, click on the icon  to enter the serial port debugging assistant, change the baud rate to 921600, select the COM port corresponding to the USB to TTL module, and then click the connect button  to connect to the COM port (most situations will automatically connect). In the one-way send text box, enter `54 20 00 ff 00 ff ff ff ff 00 ff ff 00 10 0e ff ff ff ff ff ff ff ff ff 00 ff ff ff ff 7c`, change the send interval in the timer send column to 20ms, and then check the timer send  Timed Send(ms) 20.
3. At this point, connect the GND of the USB to TTL module to the GND pin of the TOF module, and the module will switch to UART mode and start outputting data. Uncheck the timed send button, then unplug the USB to TTL module and power it on again. Click the recognition button  on the main page to recognize the module.

If the switch fails, unplug the USB to TTL module and repeat the entire process. Do not plug and unplug the GND pin multiple times while sending commands. If the module can be recognized normally but the serial output data is abnormal, it can be manually changed to UART mode in the settings page.

Q8. Whether the module can output point cloud information ?

The module can only output one distance at a time and does not currently support the output of point cloud information.

Q9. What data will the module output when it exceeds the range?

TOFSense-F:

When the range exceeds 15 meters, the error is large in the range of 15 to approximately 20 meters. Beyond the maximum range of 20 meters, the distance output is fixed at 0 meters. At this time, you can refer to the distance status indication in the data manual to determine the validity of the data.

TOFSense-F P:

When the range exceeds 25 meters, the distance output is fixed at 0 meters. At this time, you can refer to the distance status indication in the data manual to determine the validity of the data.

Q10. What is the serial port communication terminal model used by the module? Flight control, MCU without this terminal interface how to do?

The module uses a GH1.25 terminal. You can purchase GH1.25 to other terminal adapters or cut off the GH1.25-GH1.25 connection that comes with the product and weld other terminals yourself. Please refer to the data manual for wiring sequence, power supply voltage, signal line level, etc.

Q11. How to calculate the received ad 08 00 as distance value?

The data in the protocol frame is stored in little-endian mode, and it is multiplied by a certain multiple during encoding. For example, "ad 08 00" is first restored to hexadecimal data 0x0008ad, which translates to 2,221 in decimal, and divided by 1000 to become 2.221 meters.

Q12. How is the checksum calculated?

The checksum is the sum of all the bytes in the previous data, and the lowest byte is taken as the data. For example, the checksum for the data "55 01 00 ef 03" is $0x55 + 0x01 + 0x00 + 0xef + 0x03 = 0x0148$, so the checksum is 48. Therefore, the complete data of this frame is 55 01 00 ef 03 48.

Q13. Why cannot I communicate in IIC mode?

In IIC mode, it is recommended to use open drain mode output for SDA and SCL pins of the device, and there should be pull-up resistors on the bus at this time. When communicating, it is necessary to write functions such as start, end, read, write, and reply according to the standard IIC communication timing. When communicating with the TOF module, refer to the NLink_TOFSense_IIC_Frame0 protocol in the user manual to read and write registers. It is particularly important to note the shifting of the 7-bit slave address and the addition of the read-write bit transmission.

Q14. What if there is an error or no data when compiling the ROS driver package

Before using the ROS driver package, the user needs to read the README.MD document in the driver package and follow the steps and precautions in the document. The user can also refer to the "ROS Driver Application Graphic Tutorial" on the official website for use.

9 Reference

[1] TOFSense-F_Datasheet.pdf

10 Abbreviation and Acronyms

Table 6: Abbreviation and Acronyms

Abbreviation	Full Title
TOF	Time of Flight
FOV	Field of View
UART	Universal Asynchronous Receiver/Transmitter
IIC	Inter-Integrated Circuit