

# CMUcam4

## Board Layout and Ports

For the Lextronic CMUcam4 Rev A

### Board Layout

The CMUcam4 has a two-port servo controller (capable of 1  $\mu$ s resolution at a 50 Hz refresh rate), power LED, auxiliary LED, TTL UART (capable of up to 250,000 bits per second – by default 19,200 bits per second), and analog video generator (capable of NTSC or PAL output). The board layout for Lextronic CMUcam4 Rev A is shown below.

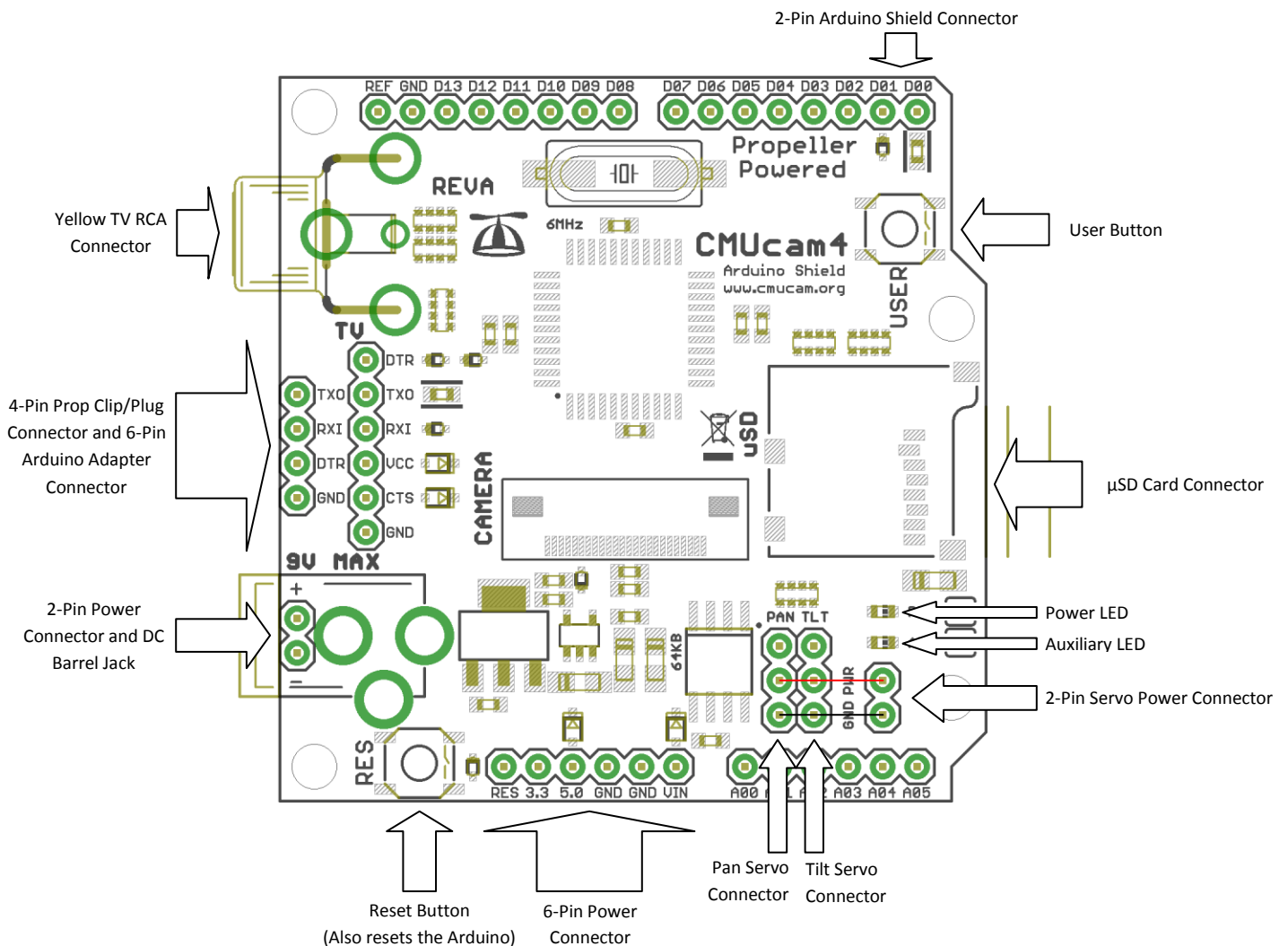

## Port Information

- **Power Connectors**
  - The camera board can be powered in five different ways. Either from the VCC pin on the 6-pin serial connector, the 2-pin power connector underneath the DC barrel jack, the DC barrel jack, the 5.0 volt pin on the 6-pin power connector, and/or the VIN pin on the 6-pin power connector. The 3.3 volt pin on the 6-pin power connector does not power the camera board. The power supply for the camera board should be able to deliver at least **250 mA** at between **4V to 9V DC**.
  - **Warning:** Do not connect a power supply to the 2-pin power connector underneath the DC barrel jack and a different power supply to the DC barrel jack at the same time. This will cause a short.
- **Serial Connectors**
  - The camera board can be communicated with in three different ways. Either from the 2-pin Arduino Shield serial port connection, the 6-pin Arduino Adapter serial port connection, or the 4-pin Prop Clip/Plug serial port connection. The serial data from the 2-pin Arduino Shield port and the 6-pin Arduino Adapter port (the 4-pin Prop Clip/Plug port) are logically ANDed together.
  - **Warning:** Do not connect a serial adapter to the 6-pin Arduino Adapter port and a different serial adapter to the 4-pin Prop Clip/Plug port at the same time. This will cause a short.
- **Camera Connector**
  - The camera board has a camera connector designed for the [OmniVision OV9665FSL](#) camera module. Removing the camera module from the camera board may damage the camera module.
- **Servo Connectors**
  - The camera board has a pan and a tilt servo connector. The pan and tilt servo connectors can be used to drive a pan and a tilt servo or be used as general-purpose inputs/outputs (GPIOs). The 2-pin servo power connector right next to the pan and tilt servo connectors provides power to the pan and tilt servo connectors only, and does not power the camera board. Be careful, not to reverse the power to the 2-pin servo power connector. Doing so may damage any servo connected to the pan and tilt servo connectors.
- **TV Connector**
  - The camera board has a yellow RCA TV connector for analog video output in either NTSC or PAL B/D/G/H/K/I. PAL N and PAL M are not supported. Inserting or removing a RCA cable from the yellow RCA TV connector while the power is on may halt or reset the camera board. Please hold the reset button (or turn the power off) while inserting or removing the RCA cable to ensure that the camera board firmware does not halt or reset.
- **μSD Connector**
  - The camera board has a μSD card connector and a FAT16/FAT32 full file system driver library for accessing μSD and μSDHC cards (μSDXC cards are not FAT16/FAT32 compatible). Inserting or removing a μSD or μSDHC card while the power is on may halt or reset the camera board. Please hold the reset button (or turn the power off) while inserting or removing the μSD or μSDHC card to ensure that the camera board firmware does not halt or reset.